

techno Metal Post



TECHNICAL DOCUMENT



HELICAL PILE FOUNDATIONS

technoMetalPost
HELICAL PILE FOUNDATIONS

TABLE OF CONTENTS

INTRODUCTION	04
A UNIQUE PRODUCT	05
THE ADVANTAGES	06
SELECTION TABLE	07
TECHNICAL SPECIFICATIONS	08
FOUNDATION STABILIZATION AND UNDERPINNING	10
LOAD TEST	11
LIFESPAN EXPECTANCY	12
ENGINEERING TEAM	13
CERTIFICATIONS	14
CONFORMITY CERTIFICATES	15
INSTALLATION EQUIPMENT	16
RESIDENTIAL PROJECT	18
COMMERCIAL PROJECT	19



INTRODUCTION

ABOUT US

Techno Metal Post is a Canadian-based company founded in 1993, with headquarters in Thetford Mines, Quebec. Our network has grown to include over 175 dealers located throughout North America and Europe, and to date, our trained and certified installers have completed over 500,000 projects. Currently, our company has five manufacturing plants for piles and specialized equipment, including four in Quebec and one in France, with a workforce of over 100 people who contribute daily to our success. Techno Metal Post also boasts an exceptional engineering service and a cutting-edge R&D department exclusively serving its dealer network.

OUR DEALERSHIP NETWORK

The quality and drive of Techno Metal Post's international operations can be summed up in one phrase: our dealer network. This network, now made up of 175 dealers in 9 countries (Canada, USA, France, Belgium, Luxembourg, Poland, England, Spain, Switzerland), is what gives Techno Metal Post a worldwide reputation. Each dealer undergoes rigorous training to meet the construction regulations of their country, enabling us to ensure high-quality standards for every installation completed by a member of the Techno Metal Post team.

OUR RESIDENTIAL AND COMMERCIAL PROJECTS

Techno Metal Post simplifies life and construction by providing an alternative foundation solution for all types of construction projects. Whether it be residential or commercial, Techno Metal Post adapts to your project requirements.

OUR INSTALLATION EQUIPMENT MAKES ALL THE DIFFERENCE

From the very beginning, Techno Metal Post recognized that investing in the production of their own specialized helical pile installation equipment would give them a competitive edge. Our mechanical engineering team designs and manufactures some of the most versatile equipment available on the market. In an ongoing basis, our engineers are always on the lookout for new features and improvements that can be added to our machines to make the installation process even more reliable and efficient in the field. Considering that each helical pile foundation project is unique, Techno Metal Post has developed machines of different sizes, performance levels and capacities. Regardless of the machine used, they are all designed to perform rigorous and reliable work. Each model is equipped with a torque measurement system. Thanks to this information, our certified installers know the precise load-bearing capacity of each pile installed.



R2D

The smallest and lightest machine that can install helical piles in just about any location imaginable. Do not underestimate its size; this machine is surprisingly powerful!



EM1 / EM2

The mid-size tracked model offers more power when needed. This machine can access any job site more easily than normal-sized hydraulic equipment and will complete the installation faster with better precision.



ET1

The heavy-duty workhorse for industrial jobs. When engineers request higher load capacities, the ET1 is used. This machine also provides a much longer reach.

A UNIQUE PRODUCT

HELICAL PILES

The « Techno Metal Post » helical pile resembles a large screw that is installed into the ground by a specialized machine until it reaches a layer of soil with the required load-bearing capacity, to support your structure.

Our team favors the purchase of Canadian steel and the manufacturing of helical piles in Quebec. Each pile is made of structural steel and compliant with ASTM A500 Grade C, CAN/CSA-G40.21 standards, and is welded following CSA W47.1 and W59 standards. Their design allows for an optimal use of the soil's capacities. They have been load-tested according to ASTM-D1143 and ASTM-D3689 standards in various types of soils around the world.

Various pile and helix sizes have been designed to ensure each project benefits from maximum support. Our engineering team is happy to assist in determining the type of helical pile best suited for your project.

TOP PLATE BRACKET

Top plate bracket systems are available to support beams for patios and other residential, commercial and industrial projects. Techno Metal Post has also developed support systems using rebar when piles are used with concrete foundations. For project-specific requirements, the production team can manufacture any custom-made support system, even for underpinning work.

OUR EXCLUSIVE GREEN SLEEVE

Our exclusive green sleeve which is custom-sized, is fitted around the pile at the time of installation. In situations where there are freeze/thaw cycles or swelling clay, the sleeve is designed to glide along the pile shaft, adapting to any ground movements. Meanwhile, the pile itself remains stable, ensuring the stability of your structure throughout the year.

ENGINEERING

Our engineering department handles the analysis and validation process of your projects. Our engineers will then determine which piles to use according to the structure being supported and the characteristics of the soil.

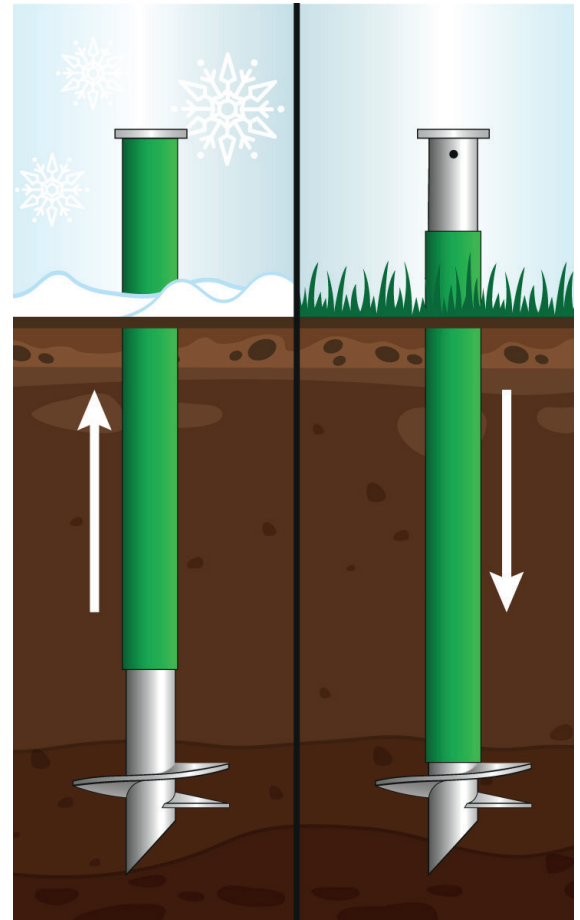

THE ADVANTAGES



NO EXCAVATION

Installing Techno Metal Post's helical piles requires no excavation or backfilling. They are installed with minimal site disruption to your property, resulting in reduced clean-up time and/or landscape work costs.



QUICK & SIMPLE

The piles can be installed in just a few hours. No excavation or concrete pouring is required, so you can start building once they have been installed.



WORLDWIDE CERTIFIED TECHNOLOGY

Our technology is certified and accredited by the relevant authorities in several countries. Our quality and reliability are also recognized by thousands of construction professionals and customers around the world.



STRONG, SOLID AND DURABLE

Our helical piles are designed according to the highest engineering and quality standards. As a result, they are guaranteed to withstand heavy loads.

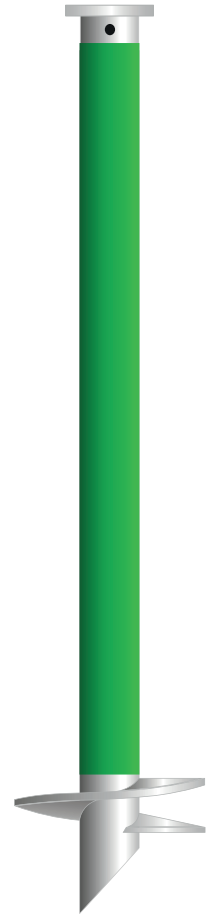

MEETS CONSTRUCTION STANDARDS



GUARANTEED STABILITY



SELECTION TABLE

MODEL (OUTSIDE, DIAMETER)	PROJECT TYPE	MAXIMUM BEARING CAPACITY								LATERAL CAPACITY ⁶		FACTORED BENDING RESIS- TANCE	
		COMPRESSION ^{1 2 4 5}				TENSION ^{1 3 4}				SLS		(LB-PI) (KN-M)	
		SLS ⁷		ULS ⁸		SLS ⁷		ULS ⁸					
		(LB)	(KN)	(LB)	(KN)	(LB)	(KN)	(LB)	(KN)	(LB)	(KN)		
P1 (O.D. 1.9 in / 48.3mm)	Light Residential (deck without roof, stairs, etc.)	6,800	30	9,520	42	3,400	15	4,760	21	500	2.2	1,010	1.4
P2 (O.D. 2.4 in / 60.3mm)	Medium Residential and Light Commercial (deck, carport, sunroom, single-story, re- sidential addition, etc.)	11,000	49	15,400	69	5,500	24	7,700	34	1,000	4.4	1,785	2.4
P2.5 (O.D. 2.875 in / 73mm)	Medium Residential and Light Commercial (deck, carport, sunroom, residential addition, sign, new construction, boardwalk, etc.)	20,000	89	28,000	125	10,000	44	14,000	62	1,500	6.7	4,057	5.5
P3 (O.D. 3.5 in / 88.9mm)	Heavy Residential, Light to Medium Commercial and Industrial (two storey residential addition, cottage, sign, light post, solar panel, new construc- tion, underpinning, boardwalk, tie-back, carport, etc.)	33,750	150	47,250	210	16,875	75	23,625	105	2,250	10	6,454	8.8
P4 (O.D. 4.0 in / 101.6mm)	Heavy Residential, Light to Medium Commercial and Industrial (cottage, sign, light post, solar panel, new construction, boardwalk, tie-back, bollard, etc.)	45,000	200	63,000	280	22,500	100	31,500	140	2,700	12	9,057	12.3
P3HD (O.D. 3.5 in / 88.9mm)	Heavy Residential, Light to Heavy Commercial and Industrial (new construction, underpinning, tie-back, etc.)	45,000	200	63,000	280	22,500	100	31,500	140	2,250	10	9,411	12.8
P4HD (O.D. 4.0 in / 101.6mm)	Heavy Residential, Light to Heavy Commercial and Industrial (new construction, underpinning, tie-back, etc.)	50,625	225	70,875	315	25,313	113	35,438	158	2,700	12	13,165	17.9
P5 (O.D. 5.6 in / 141.3mm)	Heavy Residential, Light to Heavy Commercial and Industrial (cottage, sign, light post, new construction, boardwalk, solar panel, bollard, retaining wall, etc.)	50,625	225	70,875	315	25,313	113	35,438	158	4,500	20	21,507	29.2
P6 (O.D. 6.6 in / 168.3mm)	Heavy Residential, Light to Heavy Commercial and Industrial (sign, light post, new construction, solar panel, bollard, retaining wall, etc.)	50,625	225	70,875	315	25,313	113	35,438	158	5,625	25	33,876	45.9

1. The bearing capacity values in the selection table are an indication and must be validated on-site according to the soil conditions encountered and the driving torque attained during installation.

2. The compression load capacity (SLS) is determined by the driving torque which is provided by the installation equipment when installing the piles.

3. The tension load capacity is obtained according to the driving torque which is attained during installation and according to the penetration depth of the pile. For tension applications, contact the TMP Engineering Department.

4. The maximum compression/tension loads presented in the selection table to limit the settlement to 12 mm (1/2 inch).

5. When the helical pile is laterally unsupported (very loose soil/soft, liquifiable soil, water and wind), the structural strength of the pile must be approved by the TMP Engineering Department.

6. The lateral capacity values are just indicative. They are based on dense granular soil, a free head condition of the pile, an above-ground height of the piles of 150 mm (6 inches) and with the application of only a lateral load. For applications with lateral loads, contact the TMP Engineering Department.

7. The compression load capacity (SLS) values are based on a minimum safety factor of 2 on the ultimate geotechnical resistance.

8. Factored ultimate geotechnical resistance at ULS.

Comments:

- For all technical questions, please contact the TMP Engineering Department at 418 338-8735, or via email at eng@technometalpost.com

- Larger diameter Techno Metal Post piles can be used for applications requiring a lateral or bending resistance higher than shown in the selection table.

TECHNICAL SPECIFICATIONS

HELICAL PILES

EXAMPLE: MODEL P3 - HSS 88.9 MM X 5.5 MM (3.5" X 0.216")

Techno Metal Post's helical pile model P3 is the most commonly used pile for both pre-build projects and the stabilization of existing structures. This product having a thickness of 5.5 mm, is also available in different lengths and various helix diameters. The helix diameter is determined by the type and capacity of the soil, as well as the loads that need to be supported.

Techno Metal Post also manufactures several other types of helical piles (P1 to P10), to meet your project requirements.

Shaft

Wall Thickness	0.216" (5.49 mm)
Round HSS Outside Diameter	3.5" (88.9 mm)
Available Standard Lengths	5'-3" (1.6 m) / 7'-0" (2.1 m) / 10'-6" (3.2 m)

Load Specifications

Max. Allowable Capacity*	33.75 kips (150.0 kN)
--------------------------	-----------------------

* Higher load ratings could be considered with site-specific engineering.

Technical Specifications

Commonly Used Structure	Heavy Residential
	Light to Medium Commercial
	Industrial
Code Evaluation	Listed per CCMC 13059-R
Standard Steel	ASTM A500 Grade C Fy=51 ksi min (350 MPa)
Black Steel Design Life	min. 50 years per CCMC 13059-R
Coating	Galvanized or Black Steel
Galvanization Compliance	ASTM A123/A123M
Additional Corrosion Protection	Cathodic Protection System available

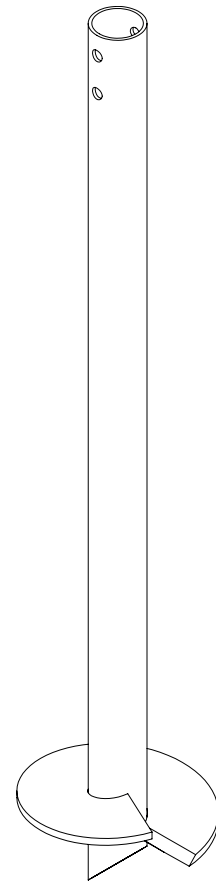

Helix

Pitch	3" (76.2 mm) / 5" (127 mm)
Thickness	0.5" (12.7 mm)
Standard Steel	CSA G40.21-44W Fy=44 ksi min (300 MPa)
Coating	Galvanized or Black Steel
Multiple Welded Helix	Available
Helix Size*	8" (203 mm) to 24" (610 mm)

* Other sizes available upon request.

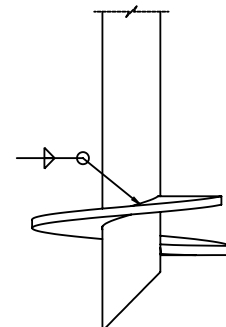

TECHNICAL SPECIFICATIONS

TOP PLATE BRACKET

There are several support plates available that enable the connection between the pile and the supported structure. We offer a range of standard products, as well as custom solutions to meet your needs. Here are just a few examples.

COMPONENT SPECIFICATIONS	
Steel	Standard: CSA G40.21 - 44W - Steel
Coating	Available with a hot dipped galvanization coating compliant with ASTM A123 or Bare steel

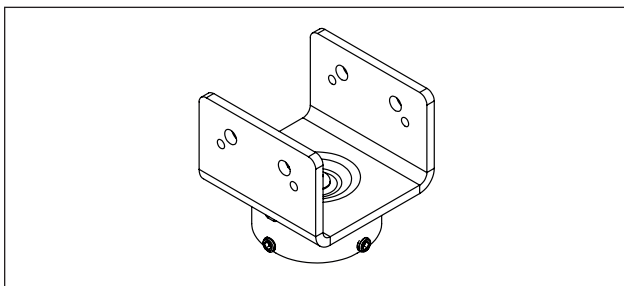
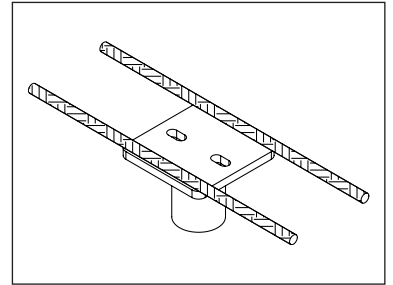

FOUNDATION STABILIZATION AND UNDERPINNING

Many factors can help you spot a foundation problem: cracks on the exterior or interior walls, cracks on a concrete floor, windows and doors that do not open properly, or a chimney that has started to pull away from the wall of the house. Our helical piles are screwed into the ground under your structure until they reach dense and compact soil with the desired bearing capacity. Steel foundation brackets are bolted to the bottom of the existing foundation wall and then welded to the piles. And so, the weight of the structure is directly and permanently supported by the piles. We can also realign or gradually raise the foundations depending on the nature of the problem. Here are the different support systems used for this type of work.

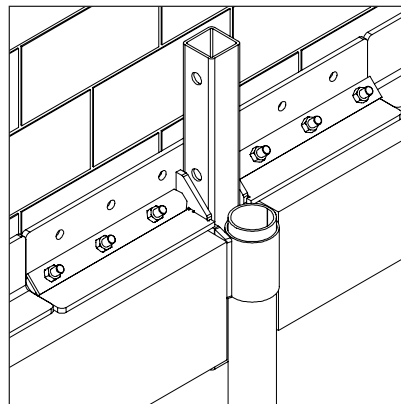
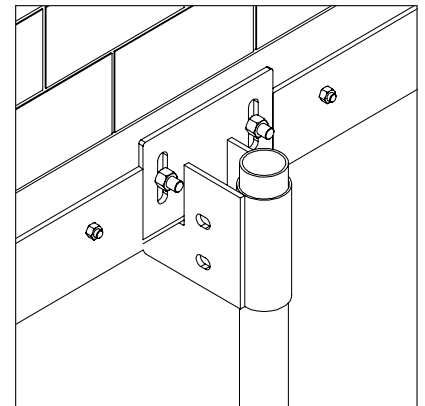
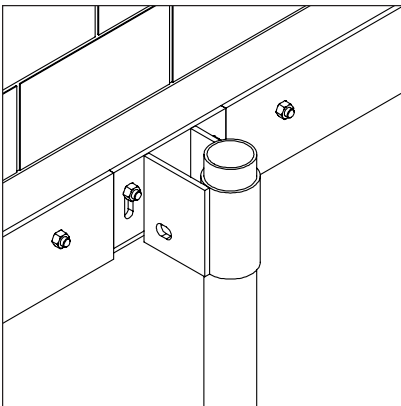
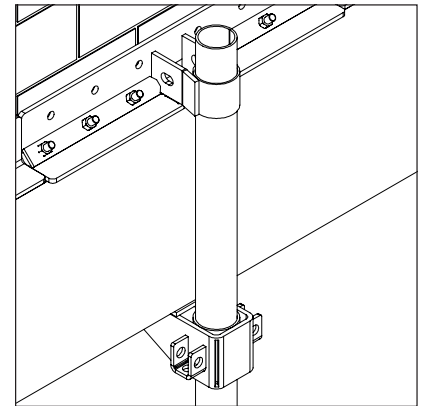
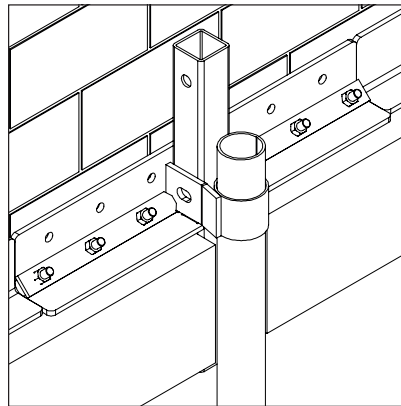
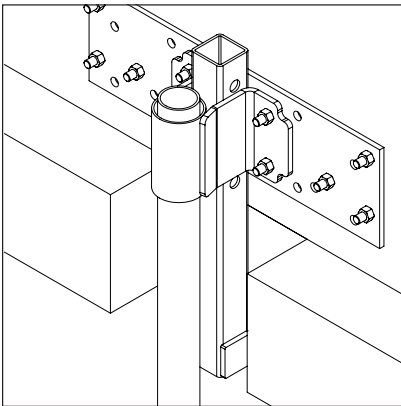

LOAD TESTS

PILES AND SUPPORT PLATES

Our piles have been tested hundreds of times in different types of soil across Canada, the USA and Europe. Compression, tension and lateral load tests can be performed on installed piles at the customer's request, in order to confirm their load-bearing capacity.



TECHNO METAL POST HELICAL PILES
ARE GUARANTEED AND CERTIFIED

LIFESPAN EXPECTANCY

Each pile is manufactured from structural steel in compliance with ASTM A500 Grade C and CAN/CSA-G40.21-2013 standards. The Techno Metal Post system is designed to ensure a minimum 50-year foundation lifespan, in accordance with current standards.

TECHNO METAL POST USES **THREE METHODS** THAT EXTEND AND GUARANTEE THE LIFESPAN OF ITS PILES:

EXTRA TUBE WALL THICKNESS

Firstly, the extra steel thickness that forms the wall of Techno Metal Posts is incorporated into the structural design of our piles. This method involves neutralizing part of the pile shaft thickness in anticipation of a possible thickness reduction due to corrosion.

GALVANIZATION

Piles can be protected against corrosion by hot-dip galvanizing in compliance with the ASTM A123-2013. Galvanizing extends the pile's lifespan. It is particularly effective in the above ground section and has the added advantage of an enhanced aesthetic finish.

CATHODIC PROTECTION

In keeping with Techno Metal Post's philosophy of offering durable, solid products, cathodic protection technologies have been specially developed to provide additional protection for helical piles, even in corrosive soils. The Techno Metal Post cathodic protection system, installed at the same time as the piles, maintains their integrity for the desired length of time.

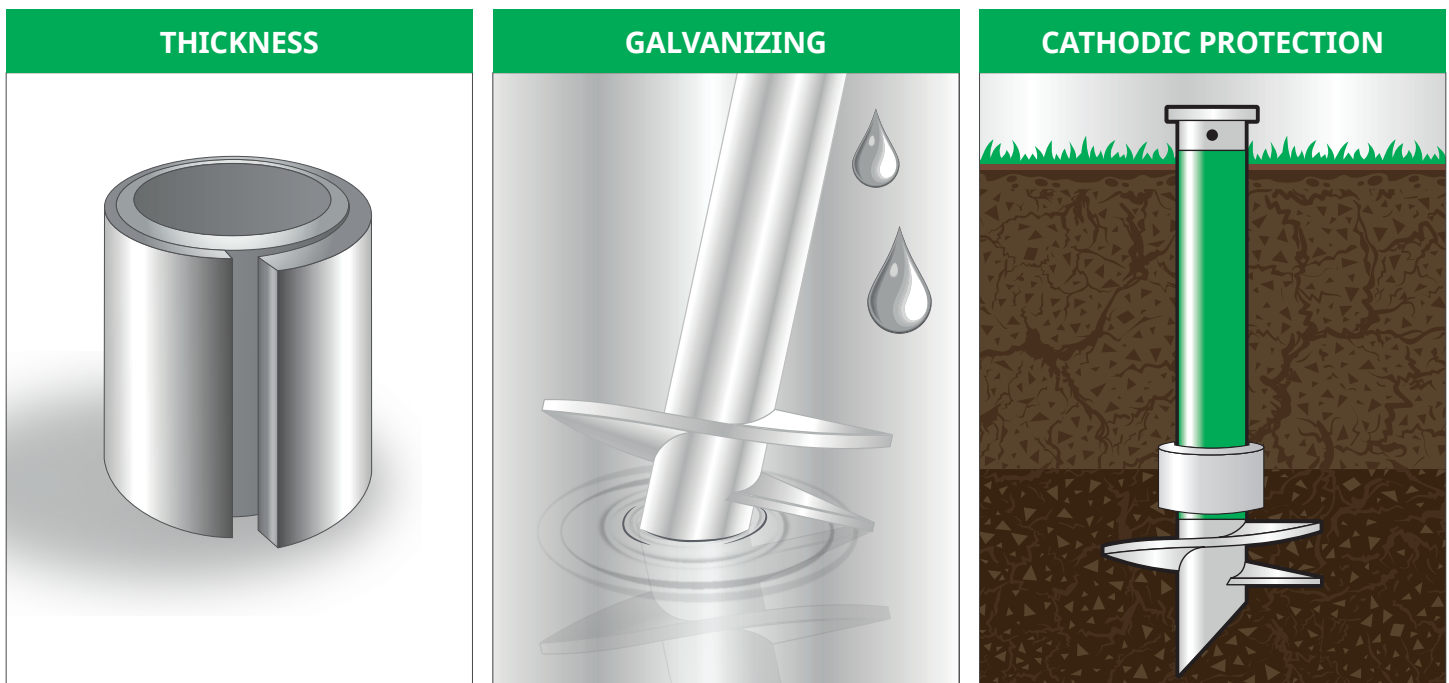

ENGINEERING TEAM

Our **engineering team**, specialized in geotechnical and structural engineering, is able to provide personalized service and assistance to determine the correct type of piles for each of your projects. Techno Metal Posts are designed in compliance with current standards and with our experience acquired over the past 30 years.



RAPHAËL VACHON
Engineer (Canada)



LUDOVIC FORTIER-ROBERGE
Engineer (Canada)



VALÉRIE GROLEAU
Engineer (Canada)



JÉRÔME CHABOT
Engineer (Canada)



JAMES A. CHERRY
Engineer (USA)



MICHAEL HUTSENPILLER
Engineer (USA)



STÉPHANE DE FRANSSU
Engineer (France)



SÉBASTIEN PLANQUART
Engineer (France)



ZUNG NGUYEN
Engineer (France)

CANADA CERTIFICATIONS

TECHNICAL CERTIFICATIONS - AN ASSURANCE OF QUALITY AND RELIABILITY

TMP has worked tirelessly to obtain the required accreditation and acceptance of its products throughout the world. Our engineers have spent countless hours ensuring that our products meet the strictest standards. TMP is the first helical pile company in the world to be recognized and to receive certifications from multiple countries.

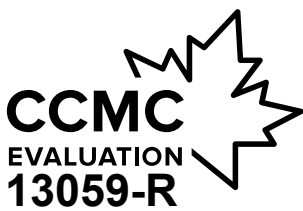

CANADIAN CONSTRUCTION MATERIALS CENTRE (CCMC) EVALUATION REPORT CCMC 13059-R

In 2002 (and renewed in 2018), Techno Metal Post received certification from the Canadian Construction Materials Centre (CCMC) attesting that Techno Pieux/ Techno Metal Post products comply with the requirements of the National Building Code of Canada (NBC).



ISO 9001 EVALUATION REPORT #481

ISO 9001:2015 specifies requirements for a quality management system when an organization:

- a) needs to demonstrate its ability to consistently provide products and services that meet customer and applicable statutory and regulatory requirements, and
- b) aims to enhance customer satisfaction through the effective application of the system, including processes for improvement of the system and the assurance of conformity to customer and applicable statutory and regulatory requirements.



CANADIAN WELDING BUREAU (CWB) CSA W47.1

Techno Metal Post is also certified by the Canadian Welding Bureau in division 2.

WORLDWIDE CERTIFICATIONS



United States: Techno Metal Post has received an evaluation report (ESR # 3418) from the ICC Evaluation Service (ICC-ES)..



IAPMO UES ER-481

United States: Since 2018, Techno Metal Post has been the first helical pile company in the world to receive the International Association of Plumbing and Mechanical Officers (IAPMO) ER-481 seal of approval.



France: Since 2006, Techno Metal Post has been the first helical pile company to benefit from a technical assessment issued by the Commission Chargée de Formuler des Avis Techniques (CCFAT) N°3/16-873.



Europe: Techno Metal Post was the first helical pile company to be certified as meeting the requirements of European standard EN 1090-1:2009 + A1:2011 / Execution of steel structures class 2, EN 1090-2.



United Kingdom: Techno Metal Post is the first to receive the BBA Approval Certificate (Certificate 18/5477), which is recognized by building authorities, government departments, architects, designers and industry insurers.

INSTALLATION EQUIPMENT

SPECIFICATIONS

Our mechanical engineering team designs and manufactures cutting-edge installation equipment to deliver reliable, efficient on-site installation. Our equipment also provides precision installation to ensure proper load transfer to the pile. In addition, the speed at which we install our equipment means that site delivery is unmatched. Our installation equipment is only available through the Techno Metal Post network.



EM1

Dimensions : 93" x 48" x 66" (2,362 mm x 1,219 mm x 1,676 mm)

Weight : 4,464 lbs (2,025 kg)

Maximum mast height : 145" (3,683 mm)

Mast rotation : 360°

Minimum clearance required for installation : 8" (203 mm)

Maximum compressive bearing capacity per installed pile : ± 150 kN

Maximum torque : ± 9,000 ft-lb



EM2

Dimensions : 106" x 48" x 68" (2,692 mm x 1,219 mm x 1,727 mm)

Weight : 6,000 lbs (2,722 kg)

Maximum mast height : 147" (3,733 mm)

Mast rotation : 360°

Minimum clearance required for installation : 8" (203 mm)

Maximum compressive bearing capacity per installed pile : ± 150 kN

Maximum torque : ± 9,000 ft-lb



R2D

Dimensions : 98 ½" x 29" x 59" (2,500 mm x 760 mm x 1,500 mm)

Weight : 1 653 lbs (750 kg)

Maximum mast height : 133 ⅞" (3,400 mm)

Mast rotation : ± 60°

Minimum clearance required for installation : 7" (178 mm)

Maximum compressive bearing capacity per installed pile : ± 115 kN

Maximum torque : ± 5,500 ft-lb



ET1

Dimensions : 168" x 68" x 84" (4,267 mm x 1,727 mm x 2,133 mm)

Weight : 8,900 lbs (4,572 kg)

Maximum mast height : 180" (4,572 mm)

Mast rotation : 360°

Minimum clearance required for installation : 9" (229 mm)

Maximum compressive bearing capacity per installed pile : ± 225 kN

Maximum torque : ± 14,500 ft-lb



RESIDENTIAL PROJECTS



DECKS



ADDITIONS



GARAGES / CARPORTS



HOMES / COTTAGES



OTHER

COMMERCIAL PROJECTS



INDUSTRIAL



COMMERCIAL PROPERTIES



STABILIZATION

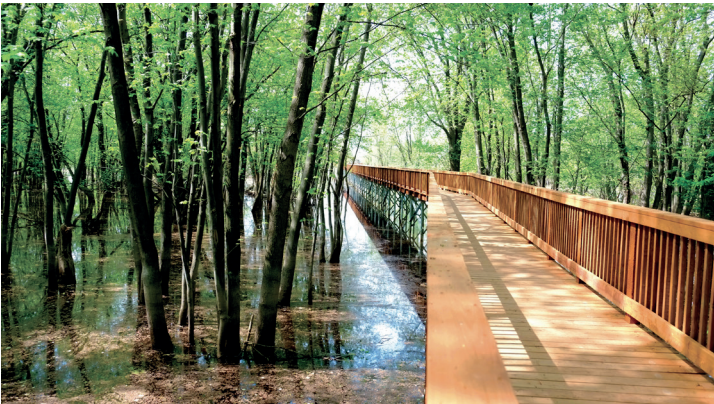

RECREATION & TOURISM



SIGNS

technoMetalPost
HELICAL PILE FOUNDATIONS



TECHNOMETALPOST.COM